



RP3 / RP3-01 Interface Profile Document

Version 1.0

1 **Table of Contents**

2 **1 Summary of Changes7**

3 **2 Scope8**

4 **3 RP3 / RP3-01 Interface Profile9**

5 3.1 Physical Layer..... 10

6 3.2 Data Link Layer 11

7 3.3 Transport Layer..... 12

8 3.4 Application Layer..... 13

9 3.4.1 RP3 Data Messages 14

10 3.4.2 RP3-01 Frame Clock Bursts 15

11 **4 Glossary..... 16**

12 **5 References 17**

13

1	List of Figures	
2		
3	Figure 1: OBSAI System Reference Architecture.....	8
4	Figure 2: Example: RP3 WCDMA / 802.16 IQ Payload Mapping	14

1	List of Tables	
2	Table 1: Data Link Layer Parameters	11
3	Table 2: Transport Layer parameters	12
4	Table 3: Application Layer Parameters	13
5	Table 4: Bit Alignment of IQ samples into RP3 IQ payload sample envelope	14
6	Table 5: RP3-01 FCB Types supported	15
7	Table 6: RP1 FCB Scheduling.....	15

1 **FOREWORD**

2 OBSAI description and specification documents are developed within the Technical
3 Working Group of the Open Base Station Architecture Initiative Special Interest Group
4 (OBSAI SIG). Members of the OBSAI TWG serve voluntarily and without
5 compensation. The description and specifications developed within OBSAI represent
6 a consensus of the broad expertise on the subject within the OBSAI SIG.

7 The OBSAI SIG uses the following terminology in the specifications:

- 8 •“shall” expresses a provision that is binding
- 9 •“should” and “may” expresses non-mandatory provisions
- 10 •“will” expresses a declaration of purpose on the part of the
11 OBSAI SIG. It may be necessary to use “will” in cases where
12 the simple future tense is required

13 Use of an OBSAI reference or specification document is wholly voluntary. The
14 existence of an OBSAI Specification does not imply that there are no other ways to
15 produce, test, measure, purchase, market, or provide other goods and services
16 related to the scope of the OBSAI Specification. Furthermore, the viewpoint
17 expressed at the time a specification is approved and issued is subject to change
18 brought about through developments in the state of the art and comments received
19 from users of the specification. Every OBSAI Specification is subjected to review in
20 accordance with the Open Base Station Architecture Initiative Rules And Procedures.

21 Implementation of all or part of an OBSAI Specification may require licenses under
22 third party intellectual property rights, including without limitation, patent rights (such a
23 third party may or may not be an OBSAI Member). The Promoters of the OBSAI
24 Specification are not responsible and shall not be held responsible in any manner for
25 identifying or failing to identify any or all such third party intellectual property rights.

26 The information in this document is subject to change without notice and describes
27 only the product defined in the introduction of this documentation. This document is
28 intended for the use of OBSAI Member’s customers only for the purposes of the
29 agreement under which the document is submitted, and no part of it may be
30 reproduced or transmitted in any form or means without the prior written permission of
31 OBSAI Management Board. The document has been prepared for use by
32 professional and properly trained personnel, and the customer assumes full
33 responsibility when using it. OBSAI Management Board, Marketing Working Group
34 and Technical Working Group welcome customer comments as part of the process of
35 continuous development and improvement of the documentation.

36 The information or statements given in this document concerning the suitability,
37 capacity, or performance of the mentioned hardware or software products cannot be
38 considered binding but shall be defined in the agreement made between OBSAI
39 members. However, the OBSAI Management Board, Marketing Working Group or
40 Technical Working Group have made all reasonable efforts to ensure that the
41 instructions contained in the document are adequate and free of material errors and
42 omissions.

43 OBSAI liability for any errors in the document is limited to the documentary correction
44 of errors. OBSAI WILL NOT BE RESPONSIBLE IN ANY EVENT FOR ERRORS IN
45 THIS DOCUMENT OR FOR ANY DAMAGES, INCIDENTAL OR CONSEQUENTIAL
46 (INCLUDING MONETARY LOSSES), that might arise from the use of this document
47 or the information in it.

48 This document and the product it describes are considered protected by copyright
49 according to the applicable laws.

1 OBSAI logo is a registered trademark of Open Base Station Architecture Initiative
2 Special Interest Group. Other product names mentioned in this document may be
3 trademarks of their respective companies, and they are mentioned for identification
4 purposes only. Copyright © Open Base Station Architecture Initiative Special Interest
5 Group. All rights reserved. Users are cautioned to check to determine that they have
6 the latest edition of any OBSAI Specification.

7 Interpretations: Occasionally questions may arise regarding the meaning of portions of
8 standards as they relate to specific applications. When the need for interpretations is
9 brought to the attention of OBSAI, the OBSAI TWG will initiate action to prepare
10 appropriate responses. Since OBSAI Specifications represent a consensus of OBSAI
11 Member's interests, it is important to ensure that any interpretation has also received
12 the concurrence of a balance of interests. For this reason OBSAI and the members of
13 its Technical Working Groups are not able to provide an instant response to
14 interpretation requests except in those cases where the matter has previously
15 received formal consideration.

16 IPR rules defined in the chapters 4 and 5 of the OBSAI Promoter Agreements and
17 chapters 3 and 4 of OBSAI Supporter Agreements are applicable also in this Profile
18 Document.

19 Comments on specifications and requests for interpretations should be addressed to:

20 Peter Kenington
21 Chairman, OBSAI Technical Working Group
22 Linear Communications Consultants Ltd.
23 Email: pbk@linearcomms.com

1 Summary of Changes

Version	Approved by	Date	Comment	Author
1.0	OBSAI MANAGEMENT BOARD	20/05/2009	Added items from Telco 25-03-09 discussions	Christian Lanzani, Radiocomp ApS
0.7 DRAFT	RP3 PROFILE PROJECT GROUP	25/03/2009	Added items from Telco 25-03-09 discussions	Christian Lanzani, Radiocomp ApS
0.6 DRAFT	RP3 PROFILE PROJECT GROUP	28/02/2009	Added items from Telco 27-02-09 discussions	Christian Lanzani, Radiocomp ApS
0.5 DRAFT	RP3 PROFILE PROJECT GROUP	27/02/2009	Added items from NSN for discussion	Timo Viero, NSN
0.4 DRAFT	RP3 PROFILE PROJECT GROUP	06/01/2009	Added items from Telco 17-12-08	Christian Lanzani, Radiocomp ApS
0.3 DRAFT	RP3 PROFILE PROJECT GROUP	17/12/2008	Added comments from Timo	Timo Viero, NSN Christian Lanzani Radiocomp ApS
0.2 DRAFT	RP3 PROFILE PROJECT GROUP	08/12/2008	Added items from Telco MoM 26-11-08	Christian Lanzani, Radiocomp ApS
0.1 DRAFT	RP3 PROFILE PROJECT GROUP	15/11/2008	Initial Release	Christian Lanzani, Radiocomp ApS

2 Scope

The OBSAI Reference Point 3 - 01 (RP3-01) interface exists between remote RFM and LC/BBM modules of a base station.

This document describes a sub-set of recommended RP3-01 interface configuration and functionalities taken from [2] and [3] specifically intended for easier integration of the local RF block and Remote RF block units (RRU) with the Base Band Block(s) and Local Converter (LC) modules between different vendors.

This profile recommendation document is driven by the OBSAI Forum member's efforts, and its acceptance by the OBSAI community is optional, as the main reference for RP3 and RP3-01 interfaces will always be the RP3 Specification Document [1].

Adoption of the profile document features is highly recommended and will bring benefits in terms of time to market and development time, thus lowering integration time and the engineering efforts required to develop, integrate and verify OBSAI RP3 and RP3-01 compliant systems, between multiple sub-modules vendors.

Focus Area for RP3/RP3-01 Air-Interface Profiles

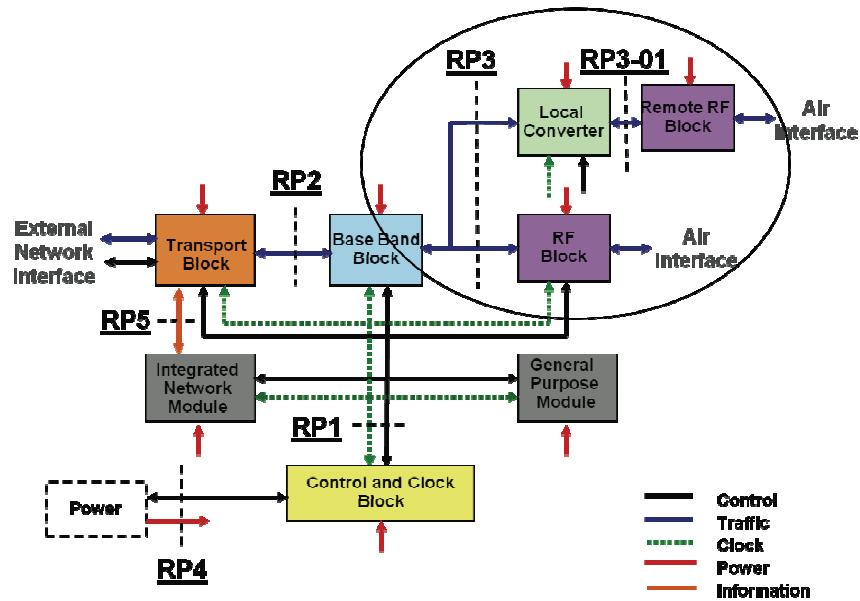

Figure 1: OBSAI System Reference Architecture

3 RP3 / RP3-01 Interface Profile

This chapter describes a recommended set of configurations and functionalities for different RP3 and RP3-01 applications.

The structure of the profile document is based on the RP3 protocol layers and architecture as in [2].

Each profile feature type may be classified as belonging to two different categories:

- **Air-interface profile feature**
 - The adoption of Air-Interface profile features will leverage interoperability between OBSAI Forum members.

- **Vendor specific profile feature**
 - The adoption of Vendor Specific profile features will leverage interoperability with a specific vendor's products.

Whenever it is not explicitly stated, a specific air-interface profile feature is also valid as vendor specific feature.

Adoption of the recommended air-interface profile features for specific applications and configuration it is optional.

1 **3.1 Physical Layer**

2 No changes to this area of the RP3 specification are required in profile work. Please
3 refer to RP3 [2].

1 **3.2 Data Link Layer**

2 This section describes some recommended configurations of the RP3 and RP3-01
3 Data Link Layer.

Item	Parameter Value(s)	Applicability	Profile Feature Type	
1	RP3 / RP3-01 Frame format	M_MG = 21 K_MG = 1 N_MG = 1920 i = 2, 4, 8 ¹	WCDMA LTE 802.16 GSM/EDGE	Air-Interface Profile
2	MAX_OFFSET (window parameter)		MAX_OFFSET value needs to be configurable, i.e. both required.	Air-Interface Profile

4

Table 1: Data Link Layer Parameters

¹ Note that the 6144 Mbps rate corresponding to i=8 does not apply for versions of the RP3 specification earlier than RP3 v.4.1

1 **3.3 Transport Layer**

2 This section describes some recommended configurations of the RP3 and RP3-01
3 transport layer.

Item		Parameter Value(s)	Applicability	Profile Feature Type
1	RP3 Addresses or address range	RP3 routers can accept full 13 bit addresses	This item is applicable only to RP3 v.4.2 compliant systems and later.	Air-Interface Profile
2	Message Multiplexing and Demultiplexer operation	Support required only in limited cases	Optionally required only in BBM / LC applications. It is not required at RRU or RFU.	Air-Interface Profile
3	Summing of RP3 messages	802.16 WiMAX	Required in case of a combiner/distributor module	Air-Interface Profile
		WCDMA-FDD		
		LTE	Summing is defined at the base station side. Summing it is not required at RRU or RFU.	

4 Table 2: Transport Layer parameters

1 **3.4 Application Layer**

2 This section describes some recommended configurations of the RP3 and RP3-01
3 application layer.

Item		Parameter Value(s)		Applicability	Profile Type	
1	Air-Interfaces	802.16 WiMAX		Based on application	Air-Interface Profile	
		WCDMA-FDD				
		LTE				
		GSM / EDGE				
2	Message transmission rules Dual Bit Map	WCDMA-FDD	DL	Optional	Air-Interface Profile	
			UL	Not required		
		LTE	DL	Not required		
			UL	Not required		
		LTE	DL	Required only for 15 MHz		
			UL	Not required		
		GSM / EDGE	DL	Not required		
			UL	Required		
3	RP3 Type field	WCDMA-FDD		Based on application	Air-Interface Profile	
		802.16				
		LTE				
		GSM/EDGE				
		RP3 Generic Type				
		Measurement				
		Control				
		Ethernet				Required
		FCB				
		Virtual HW Reset				
		RTT				
		4	Timestamp field	The time-stamp start position 0 is aligned with the air-interface boundary		Required

4

Table 3: Application Layer Parameters

1
2
3
4
5
6
7

3.4.1 RP3 Data Messages

3.4.1.1 Bit alignment of IQ samples into RP3 IQ Payload Sample Envelope

RP3 sample size is fixed and defined as in [2] according to the air-interface standard used.

In special cases, where a lower number of bits per sample is utilized, then the following method is recommended.

Item	Parameter Value(s)	Applicability	Profile Type	
1	Smaller Size IQ samples bit alignment	Any sample size < sample envelope size	Recommended	Air-Interface Profile
			Not supported	NSN Vendor Specific Profile

8

Table 4: Bit Alignment of IQ samples into RP3 IQ payload sample envelope

9
10
11
12
13
14
15
16
17

In applications where the envelope size of the sample is not fully utilized by the actual sample value, due to specific system requirements, the MSB of each sample shall be aligned with the MSB bit position of the sample envelope. All unused bit positions in the LSB part of the envelope shall be set with zeroes (0s). One advantage of the alignment to MSB is that the digital power level will be the same in the system and the resolution may be increased by treating the LSBs as valid bits. DL and UL links may have independent sample sizes.

Example in Figure 2: Mapping of WiMAX or WCDMA/LTE 14 bit size sample into 16 bits sample envelope

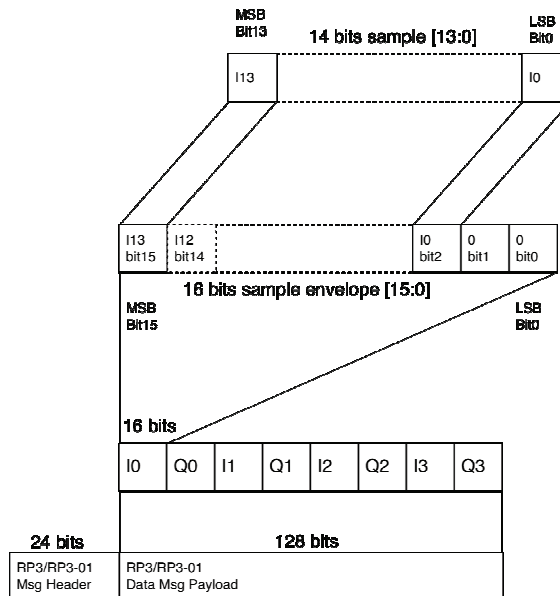

18
19
20

Figure 2: Example: RP3 WCDMA / 802.16 IQ Payload Mapping

1 4 Glossary

2

Abbreviations

BBM	Baseband module
BTS	Base transceiver system
CCM	Control and clock module
DL	Downlink direction from BTS to RRUs
FCB	Frame Clock Burst
HW	Hardware
LC	Local Converter that interfaces to RP3 and RP1 and combines them to RP3-01 and vice versa. Local Converter is referred to as Local cabinet in [2].
LSB	Least Significant Bit
LTE	Long Term Evolution
MSB	Most Significant Bit
RP3-01	Extension of RP3 protocol where RP1 data is mapped into RP3 messages
RFM	Radio Frequency Module
RRU	Remote RF unit. RRU is referred to as Remote cabinet in [2].
SFN	System frame number
UL	Uplink direction from RRUs to BTS

1 **5 References**

- 2 [1] Open Base Station Architecture Initiative, BTS System Reference Document.
- 3 [2] Open Base Station Architecture Initiative, RP3 Specification Document v.4.1.
- 4 [3] Open Base Station Architecture Initiative, Reference Point 1 Specification, v.2.1.
- 5 [4] Open Base Station Architecture Initiative, Baseband Module Specification.
- 6 [5] Open Base Station Architecture Initiative, RF Module Specification.
- 7 [6] Open Base Station Architecture Initiative, BTS System Reference Document, Appendix F.